

## INDUSTRIAL DIESEL ENGINE

# Kubota Super Mini Series (3-Cylinder)

# D902-E4B



### Rated Power

**18.5 kW @ 3600 rpm**

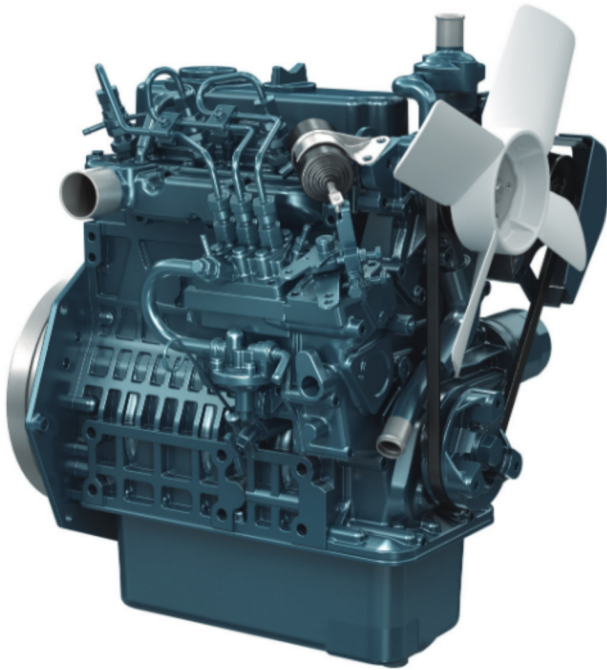

Photograph may show non-standard equipment.

### Performance Curves

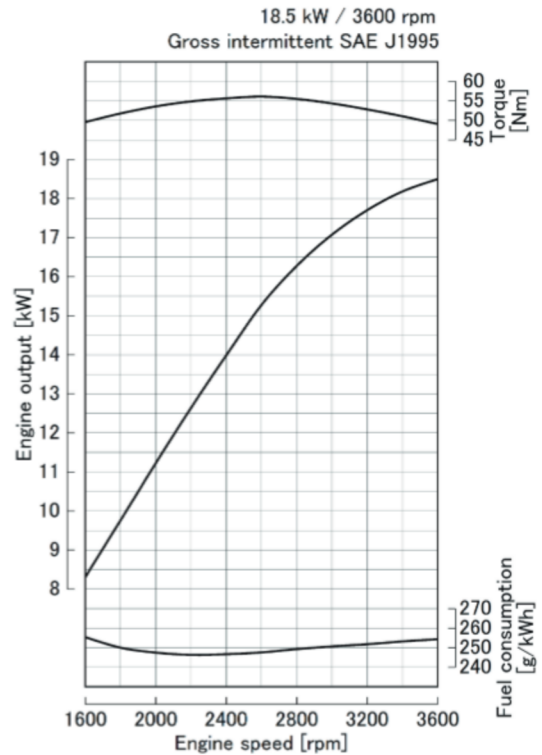

### Features and Benefits

#### Emissions

The Kubota Super Mini Series features compact multi-cylinder liquid cooled industrial diesel engines which comply with EPA / CARB Tier 4 emissions regulations.

#### Durable Power

The D902 engine delivers the highest output among the Kubota Super Mini Series engines.

By expanding the bore and stroke, Kubota has increased engine displacement while maintaining the same footprint as the D722 engine. The use of an extended shallow oil pan keeps the engine height lower than that of the D722, providing a compact engine package.

The cooling water passages between the cylinder bores features Kubota's original casting technology as a countermeasure against the heat load caused by high power density, providing both superior endurance and reliable engine performance.

This engine offers a seamless transition from E3 to E4 by maintaining the same level of performance and physical characteristics.

Alternative fuel engines WG972-G (gasoline) and WG972-GL (dual fuel: gasoline / LPG) are available with the same footprint as the D902 engine.

#### Clean and Quiet Power

Kubota's original E-TVCS (Three Vortex Combustion System) has been further improved for cleaner emissions. The piston recess has been optimized to achieve lower particulate matter (PM) levels at an extremely small size. The half-float valve cover and MoS<sub>2</sub>-coated pistons reduce noise levels and decrease vibrations transmitted from the valve area.

# D902-E4B

## Engine Specifications

<b>Engine model</b>		D902-E4B
<b>Emission regulation</b>		EPA/CARB Tier 4 (NRTC/NTE test mode) + EU Stage V
<b>Type</b>		Vertical, water cooled 4-cycle diesel engine
<b>Cylinders</b>		3
<b>Bore and stroke</b>	mm (in)	72.0 x 73.6 (2.83 x 2.90)
<b>Displacement</b>	L (cu.in)	0.898 (54.80)
<b>Aspiration</b>		Naturally aspirated
<b>Aftertreatment</b>		-
<b>Rated output / speed</b> *1	kW (HP) / rpm	18.5 (24.8) / 3600
<b>Maximum torque / speed</b> *1	Nm (lb-ft) / rpm	56.1 (41.4) / 2600
<b>Combustion system</b>		Indirect injection
<b>Fuel system</b>		In-line pump
<b>Length x Width x Height</b> *2 (without aftertreatment unit)	mm (in)	434 x 401 x 544 (17.1 x 15.8 x 21.4)
<b>Length x Width x Height</b> *3 (with aftertreatment unit)	mm (in)	-
<b>Dry weight</b> *3	kg (lbs)	72 (159)

Specifications are subject to change without notice.  
Dimensions and dry weight are according to Kubota's standard specification.  
Dimensions and weight depend on completed specifications.

\*1: SAE J1995 gross intermittent

\*2: Exclude cooling fan and exclude aftertreatment unit

\*3: Exclude cooling fan and include aftertreatment unit on engine

## Dimensions

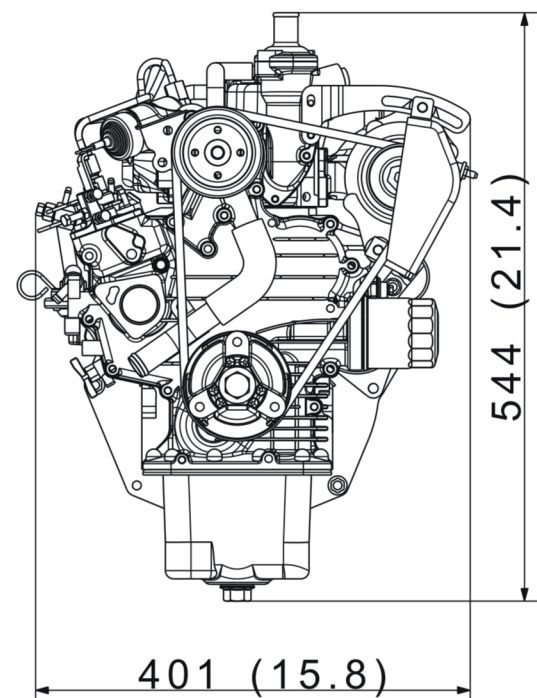
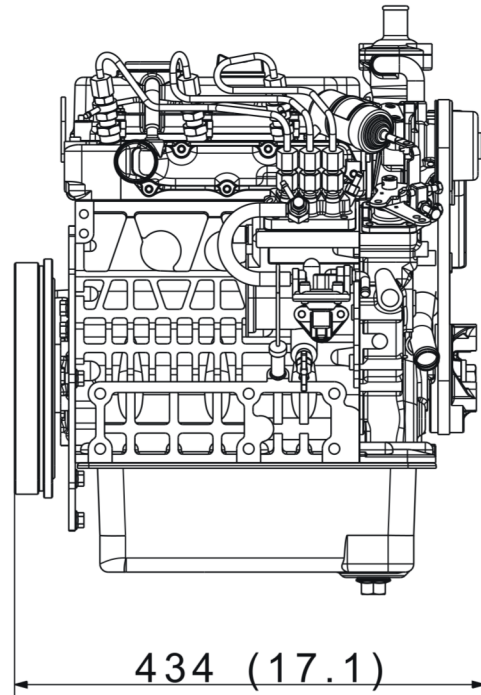

## Kubota Corporation

2-47, Shikitsuhigashi 1-chome Naniwa-ku, Osaka, 556-8601 Japan

<https://global.engine.kubota.co.jp/en/>

ASPD902-E4B1902-R1-I-178040